



## INTERNATIONAL APPLICATION PUBLISHED UNDER THE PATENT COOPERATION TREATY (PCT)

|  |                            |  |    |            |                        |    |            |                           |    |   |
|--|----------------------------|--|----|------------|------------------------|----|------------|---------------------------|----|---|
| (51) International Patent Classification <sup>6</sup> :<br>A61B 17/22, A61F 2/01   | A1                         | (11) International Publication Number: <b>WO 97/27808</b><br>(43) International Publication Date: 7 August 1997 (07.08.97) |    |            |                        |    |            |                           |    |   |
| <p>(21) International Application Number: PCT/US97/01807</p> <p>(22) International Filing Date: 31 January 1997 (31.01.97)</p> <p>(30) Priority Data:</p> <table border="0"> <tr> <td>60/011,070</td> <td>2 February 1996 (02.02.96)</td> <td>US</td> </tr> <tr> <td>60/018,715</td> <td>31 May 1996 (31.05.96)</td> <td>US</td> </tr> <tr> <td>08/723,619</td> <td>2 October 1996 (02.10.96)</td> <td>US</td> </tr> </table> <p>(71) Applicant: REGENTS OF THE UNIVERSITY OF CALIFORNIA [US/US]; 22nd floor, 300 Lakeside Drive, Oakland, CA 94612-3550 (US).</p> <p>(72) Inventors: WENSEL, Jeffrey, P.; 1605 Avocado Avenue, Newport Beach, CA 92660 (US). GOBIN, Y., Pierre; 10526 Butterfield Road, Los Angeles, CA 90064 (US).</p> <p>(74) Agent: CARPENTER, John, D.; Christie, Parker &amp; Hale, L.L.P., P.O. Box 7068, Pasadena, CA 91109-7068 (US).</p>   | 60/011,070                 | 2 February 1996 (02.02.96)   | US | 60/018,715 | 31 May 1996 (31.05.96) | US | 08/723,619 | 2 October 1996 (02.10.96) | US | <p>(81) Designated States: AU, CA, IL, JP, European patent (AT, BE, CH, DE, DK, ES, FI, FR, GB, GR, IE, IT, LU, MC, NL, PT, SE).</p> <p><b>Published</b><br/><i>With international search report.</i><br/><i>Before the expiration of the time limit for amending the claims and to be republished in the event of the receipt of amendments.</i></p> |
| 60/011,070   | 2 February 1996 (02.02.96) | US   |    |            |                        |    |            |                           |    |   |
| 60/018,715   | 31 May 1996 (31.05.96)     | US   |    |            |                        |    |            |                           |    |   |
| 08/723,619   | 2 October 1996 (02.10.96)  | US   |    |            |                        |    |            |                           |    |   |
| (54) Title: CLOT CAPTURE COIL  |                            |  |    |            |                        |    |            |                           |    |   |
| (57) Abstract  |                            |  |    |            |                        |    |            |                           |    |   |
| <p>A clot and foreign body removal device is described which comprises a catheter with at least one lumen. Located within the catheter is a clot capture coil that is connected to an insertion mandril. In one embodiment, the clot capture coil is made out of a solid elastic or superelastic material which has shape memory, preferably nitinol. The elasticity or superelasticity of the coil allows it to be deformed within the catheter and to then reform its original coil configuration when the coil is moved outside of the catheter lumen. In another embodiment the coil is a biphasic coil which changes shape upon heating or passing an electric current. Once the coil configuration has been established, the coil can be used to ensnare and corkscrew a clot in a vessel. A clot is extracted from the vessel by moving the clot capture coil and catheter proximally until the clot can be removed or released into a different vessel that does not perfuse a critical organ. Foreign bodies are similarly captured by deploying the coil distal to the foreign body and moving the clot capture coil proximally until the foreign body is trapped within the coil. By removing the device from the body, the foreign material is also removed.</p> |                            |  |    |            |                        |    |            |                           |    |   |

**FOR THE PURPOSES OF INFORMATION ONLY**

Codes used to identify States party to the PCT on the front pages of pamphlets publishing international applications under the PCT.

|    |                          |    |  |    |                          |
|----|--------------------------|----|--|----|--------------------------|
| AM | Armenia                  | GB | United Kingdom                           | MW | Malawi                   |
| AT | Austria                  | GE | Georgia                                  | MX | Mexico                   |
| AU | Australia                | GN | Guinea                                   | NE | Niger                    |
| BB | Barbados                 | GR | Greece                                   | NL | Netherlands              |
| BE | Belgium                  | HU | Hungary                                  | NO | Norway                   |
| BF | Burkina Faso             | IE | Ireland                                  | NZ | New Zealand              |
| BG | Bulgaria                 | IT | Italy                                    | PL | Poland                   |
| BJ | Benin                    | JP | Japan                                    | PT | Portugal                 |
| BR | Brazil                   | KE | Kenya                                    | RO | Romania                  |
| BY | Belarus                  | KG | Kyrgyzstan                               | RU | Russian Federation       |
| CA | Canada                   | KP | Democratic People's Republic<br>of Korea | SD | Sudan                    |
| CF | Central African Republic | KR | Republic of Korea                        | SE | Sweden                   |
| CG | Congo                    | KZ | Kazakhstan                               | SG | Singapore                |
| CH | Switzerland              | LI | Liechtenstein                            | SI | Slovenia                 |
| CI | Côte d'Ivoire            | LK | Sri Lanka                                | SK | Slovakia                 |
| CM | Cameroon                 | LR | Liberia                                  | SN | Senegal                  |
| CN | China                    | LT | Lithuania                                | SZ | Swaziland                |
| CS | Czechoslovakia           | LU | Luxembourg                               | TD | Chad                     |
| CZ | Czech Republic           | LV | Latvia                                   | TG | Togo                     |
| DE | Germany                  | MC | Monaco                                   | TJ | Tajikistan               |
| DK | Denmark                  | MD | Republic of Moldova                      | TT | Trinidad and Tobago      |
| EE | Estonia                  | MG | Madagascar                               | UA | Ukraine                  |
| ES | Spain                    | ML | Mali                                     | UG | Uganda                   |
| FI | Finland                  | MN | Mongolia                                 | US | United States of America |
| FR | France                   | MR | Mauritania                               | UZ | Uzbekistan               |
| GA | Gabon                    |    |  | VN | Viet Nam                 |

## CLOT CAPTURE COIL

### 5 Cross Reference to Related Application

The present application claims priority to U.S. Patent Application Serial No. 08/723,619, filed October 2, 1996; U.S. Provisional Patent Applications having Serial Nos. 60/011,070, filed February 2, 1996 and 60/018,715, filed May 31, 1996.

### 10 Field of the Invention

The present invention relates to medical devices that are useful in treating thromboembolic disorders and for removal of foreign bodies in the vascular system.

### Background of the Invention

15 Thromboembolic disorders, such as stroke, pulmonary embolism, peripheral thrombosis, atherosclerosis, and the like, affect many people. These disorders are a major cause of morbidity and mortality in the United States.

Thromboembolic events are characterized by an occlusion of a blood vessel. The occlusion is caused by a clot which is viscoelastic (jelly like) and is comprised of platelets, 20 fibrinogen and other clotting proteins.

When an artery is occluded by a clot, tissue ischemia (lack of oxygen and nutrients) develops. The ischemia will progress to tissue infarction (cell death) if the occlusion persists. Infarction does not develop or is greatly limited if the flow of blood is reestablished rapidly. Failure to reestablish blood-flow can lead to the loss of limb, angina pectoris, myocardial 25 infarction, stroke or even death.

Occlusion of the venous circulation by thrombi leads to blood stasis which can cause numerous problems. The majority of pulmonary embolisms are caused by emboli that originate in the peripheral venous system. Reestablishing blood flow and removal of the thrombus is highly desirable.

30 There are many existing techniques employed to reestablish blood flow in an occluded vessel. One common surgical technique, an embolectomy, involves incising a blood vessel and introducing a balloon-tipped device (such as the Fogarty catheter) to the location of the occlusion. The balloon is then inflated at a point beyond the clot and used to translate the obstructing material back to the point of incision. The obstructing material is then removed by 35 the surgeon. While such surgical techniques have been useful, exposing a patient to surgery may be traumatic and best avoided when possible. Additionally, the use of a Fogarty catheter is problematic because of the great risk of damaging the interior lining of the vessel as the catheter is being withdrawn.

5 Percutaneous methods are also utilized for reestablishing blood flow. A common percutaneous technique is referred to as balloon angioplasty where a balloon-tipped catheter is introduced to a blood vessel, typically through an introducing catheter. The balloon-tipped catheter is then advanced to the point of the occlusion and inflated in order to dilate the stenosis. Balloon angioplasty is appropriate for treating vessel stenosis but is not effective for treating acute thromboembolisms.

10 Another percutaneous technique is to place a microcatheter near the clot and infuse streptokinase, urokinase or other thrombolytic agents to dissolve the clot. Unfortunately, thrombolysis typically takes hours to days to be successful. Additionally, thrombolytic agents can cause severe hemorrhage and in many patients the agents cannot be used at all.

15 U.S. Patent Nos. 4,706,671 and 5,011,488 both describe the use of a coiled section for the removal of thromboembolic material. However, neither patent describes a device that is marketed. U.S. Patent No. 4,706,671 teaches the use of a hollow flexible elastomeric material to form the shape of the coiled section. The coiled section is hollow to allow for the insertion of a liquid into the hollow center such that the coils become stiff. U.S. Patent No. 5,011,488 teaches the use of a coiled section that is fixed on both the proximal and distal ends such that the operator of the device can change the shape and size of the coils. However, this device may be impossible to manufacture and is impossible to use in small vessels.

20 Another problematic area is the removal of foreign bodies. Foreign bodies introduced into the circulation can be fragments of catheters, pace-maker electrodes, guide wires, and erroneously placed embolic material such as thrombogenic coils. The only available retrieval devices for the removal of foreign bodies are devices which form a loop that can ensnare the foreign material by decreasing the size of the diameter of the loop around the foreign body. The use of such removal devices is difficult and sometimes unsuccessful.

25 Thus, there exists a need for the development of a device that can be easily deployed into the circulatory system for the removal of viscoelastic clots and foreign bodies. There is also a need for a device which could be used as a temporary arterial or venous filter to capture and remove thromboemboli formed during endovascular procedures.

35

**Summary of the Invention**

5 The present invention is a coil type device that is useful in removing clots and foreign bodies in vessels. The invention comprises a catheter with at least one lumen. Located within the catheter is a clot capture coil that is connected to an insertion mandril. The clot capture coil is made out of a solid elastic or superelastic material which has shape memory. The elasticity or superelasticity of the coil allows it to be deformed within the catheter and to then reform its original coil configuration when the coil is moved outside of the catheter lumen.

10 In an alternate embodiment, the coil is made out of a biphasic material which changes shape upon heating or the passage of electrical current. The coil is straight initially, and then after passing electrical current or heat the coil changes to its coil configuration.

15 Once the coil configuration has been established, the coil can be used to ensnare and corkscrew a clot in a vessel. The clot is extracted from the vessel by moving the clot capture coil and catheter proximally until the clot can be removed or released into a different vessel that does not perfuse a critical organ. The coil can also be used a temporary arterial or venous filter to capture and remove thromboemboli formed during endovascular procedures. Foreign bodies are captured by deploying the coil distal to the foreign body and moving the clot capture coil proximally until the foreign body is trapped within the coil. By removing the device from the  
20 body, the foreign material is also removed.

25

30

35

**Brief Description of the Drawings**

Embodiments of the invention will now be described with reference to the following drawings which:

FIG. 1a is a schematic illustration of an occluded artery with a microcatheter and the clot capture coil of the present invention;

FIG. 1b is a schematic illustration of an occluded artery with a microcatheter and a clot capture coil inserted through an occlusion;

FIG. 1c is a schematic illustration of the deployment of the clot capture coil within an occluded artery;

FIG. 1d is a schematic illustration of the clot capture coil of the present invention encountering a clot in an occluded artery;

FIG. 1e is a schematic illustration of the clot capture coil ensnaring the clot in an occluded artery;

FIG. 1f is a schematic illustration of the clot of FIG. 1e being moved within an occluded artery via the clot capture coil;

FIG. 1g is a cross section of the artery and the catheter of FIG. 1e along line 1g-1g.

FIG. 2a is a schematic illustration of an occluded artery and an alternate embodiment of the clot capture coil;

FIG. 2b is a schematic illustration of a microcatheter passed through a clot within an occluded artery and the extended coil of the clot capture coil within the catheter;

FIG. 2c is a schematic illustration of the deployment of the clot capture coil in an occluded artery;

FIG. 2d is a schematic illustration of a clot capture coil ensnaring a clot within an occluded artery;

FIG. 2e is a schematic illustration of the removal of a clot via a clot capture coil illustrating the corkscrewing and ensnaring effect of the coil within the viscoelastic clot;

FIG. 2f is a cross section of the artery and catheter of FIG. 2d at line 2f-2f.

FIG. 3 is an alternate coil configuration;

FIG. 4 is an alternate coil configuration;

FIG. 5 is a further coil configuration;

FIG. 6 is an additional coil configuration;

FIG. 7 is a further coil configuration;

FIG. 8 is a double helix coil configuration and a single lumen catheter;

FIG. 9 is a double helix coil configuration and a double lumen catheter;

FIG. 10a is a schematic illustration of the clot capture coil and an introducer;

FIG. 10b is a schematic illustration of a clot capture coil straightened within the inner

lumen of the introducer of FIG. 10a;

5 FIG. 11 is a plan view of the present invention being deployed within an introducing catheter with a side suction port;

FIG. 12 is a schematic view of the present invention being deployed within an introducing catheter such that the coil section is within the inferior vena cava of a patient;

10 FIG. 13 is an alternate coil configuration that is particularly useful for removing clots in a surgically created arteriovenous fistula of a hemodialysis patient;

FIG. 14 is a further coil configuration; and

FIG. 15 is another coil configuration.

15

20

25

30

35

### **Description of the Preferred Embodiments**

Turning now to FIGS. 1a-1g, a clot capture coil device 10, is generally illustrated within an artery 20 with a clot 22. The device comprises a catheter 12 with at least one lumen 14, a clot capture coil 18, and an insertion mandril 16.

The catheter 12 can be any commercially available catheter that is made out of any appropriate biologically compatible material. Typically, the catheter will have a single lumen 14 and is constructed out of a flexible elastomeric materials such as silicone, rubber, polyvinylchloride, polyurethanes, polyesters, polytetrafluoroethylene, and the like. The catheter has to be flexible enough and long enough to navigate through blood vessels to the occluded vessel 20 where clot 22 is located. Typically the catheter will range in length from about 20 to about 175 cm.

The outer diameter of the catheter can also vary. Typically the outer diameter will range from about 2 to about 10 French (one French = 0.013 inch). The inner diameter will range from about 1 to about 9 French.

The insertion mandril 16 has to be relatively stiff to support the coil 18. In the preferred embodiment, the insertion mandril is made out of stainless steel and is a solid wire of from about 0.006 to about 0.038 inches in diameter. Other materials could be used such as a hard plastic, nitinol, and the like to make the insertion mandril. The insertion mandril is 10 to 20 cm longer than the catheter such that the operator of the device (typically a physician) can control the insertion mandril by gripping the proximal end which extends from the proximal end of the catheter.

Connected to the insertion mandril is the clot capture coil 18. In one embodiment, the coil is made from a flexible solid elastic or superelastic material which has shape memory, i.e., it can deform to a straighten position and then return to a resting coil configuration. In a preferred embodiment, the coil is made out of a solid nitinol wire with a diameter of about 0.001 to about 0.038 inches. The use of nitinol in medical devices is well known in the art. Nitinol is preferred because of its superelasticity and its shape memory. However, other solid materials that are also elastic or superelastic and have shape memory could also be used such as some synthetic plastics, metallic alloys, and the like. To make the coil, the nitinol wire is wrapped around a mandrel into the coil configuration. The nitinol is then heated to an appropriate temperature such that the nitinol wire adopts the coil configuration as its resting shape upon cooling. The diameter of the coils can vary depending on the size of the vessel occluded. The diameter can range from about 1 mm for small vessels to about 30 mm for large vessels such as the pulmonary arteries or inferior vena cava. The length of the coil can also vary but typically ranges from about 3 to about 100 mm in the proximal to distal direction. Because the nitinol coil is superelastic, the coil can be extended to a completely straight configuration with the use of minimal force and then



reform to its natural resting configuration when the force is removed. In use, the coil is extended by using the insertion mandril to insert the coil and the mandril into the narrow lumen of the catheter.

5

In an other embodiment, the coil is made out of a solid biphasic material which changes shape upon heating or the passage of electric current. A presently preferred material is biphasic nitinol which has a straight configuration initially, and changes to a coiled configuration upon the passage of electric current or heating. The use of biphasic nitinol is well known in the medical arts for other purposes. The biphasic nitinol coil would be made using ordinary skill in the art such that the nitinol coil is straight initially and then forms the appropriate coil configuration. As would be apparent to a person skilled in the art, the biphasic coil could also be constructed such that the initial coil configuration is the normal shape and that the biphasic coil straightens upon passing electric current or heating. The coil dimensions would be similar to the dimension detailed above for the shape memory coil.

10

15

The coil section of either the shape memory coil or the biphasic coil can have many different configurations. Similar reference numerals are used throughout the figures to indicated similar components of the embodiments. In the embodiment illustrated in FIGS. 1a-1f, the coil is barrel shaped such that the diameter of the coils are relatively small at the distal and proximal ends of the coil and is relatively large in the center of the coil. In a typical coil configuration, the diameters of the coils range from 2 mm at the proximal and distal ends and expand to 10 mm in the center. However, other sizes are also useful depending on the relative size of the occluded vessel. At the proximal end of the coil is a small circular loop 26. In the preferred illustrated embodiment, the circular loop is placed around the stainless steel wire and is freely slidable over the wire. The distal end of the barrel shaped coil is permanently connected to the distal end 24 of the insertion mandril. Thus, in this embodiment the coil extends proximally from the distal end of the insertion mandrel. In the preferred embodiment the coil is welded onto the distal end of the insertion mandril. Other means of permanently connecting the coil could also be used such as crimping the coil, gluing the coil, screwing the coil into a screw type mount, and the like.

20

25

30

A different coil configuration is illustrated in FIGS. 2a-2f. In this embodiment, the coil 30 is connected at its proximal end to the distal end 24 of the insertion mandril 16. Thus, the coil extends distally from the distal end of the insertion mandril. The distal end 32 of the coil is free floating. The coil is conically shaped with the diameter of the coils decreasing distally to the free end 32. Embodiments where the coil is connected to the proximal end are preferred for use in removing clots from small and/or tortuous vessels as will be discussed below.

35

The size and shape of the coils can vary and different representative embodiments are illustrated in the different figures. FIG. 3 illustrates an alternate embodiment where the coil 34 is attached at its proximal end to the distal end of the insertion mandril 16. Thus, the coil extends

distally away from the distal end of the insertion mandril. The coil is shaped like an inverted cone with the diameter of the coils increasing distally. This embodiment is particularly useful  
5 for retrieving clots from small (1-2 mm diameter) vessels in the cerebral and coronary circulations. The diameter of the coils in this configuration are typically from about 1 mm to about 3 mm, could be larger depending on the relative size of the occluded vessel.

FIG. 4 illustrates a cone shaped coil 36 where the distal end of the coil is connected to the distal end of the insertion mandril. FIG. 5 is a similar embodiment to FIG. 4 except that the coil  
10 38 is wound tighter such that there are more revolutions per inch. In both FIGS. 4 and 5 the coil section extends proximally from the distal end of the insertion mandril.

FIG. 6 illustrates a different embodiment where the proximal end of the coil 42 is connected to the insertion mandril's distal end. The coil is shaped like an inverted cup which has a constant diameter until the coil reaches its most distal end where the diameter decreases.  
15

FIG. 7 is a similar embodiment to FIGS. 1a-1f except that the barrel shaped coil 40 is connected to the distal end of the insertion mandril such that the coil extends distally instead of proximally.  
20

The embodiment of FIG. 8 is a double helix coil configuration that is useful for large clot removal. The configuration is such that one continuous piece of wire is used to form the double helix configuration. Both ends of the coil 44 and 46 are connected to the distal end of the insertion mandril 16. In the preferred embodiment, both ends are welded onto the insertion mandrel 16 at weld lines 45 and 47. The coil has been heat treated such that it forms a resting double helix shape. The two helixes 48 and 50 intertwine and are connected at the top of each helix at point 52. When the double helix coil is withdrawn into the single lumen catheter by translating the insertion mandril, the helixes straighten until the coils are completely withdrawn into the catheter's lumen. By translating the insertion member in the opposite direction, the coil is forced out of the lumen of the catheter and then reforms the double helix configuration.  
25

FIG. 9 is an alternate double helix embodiment where the double helix is used in conjunction with a double lumen catheter 56. The lumens 58 and 60 each receive an insertion mandril 16 and 16'. Each insertion mandril in turn is permanently connected to one of the ends of the coil. At the proximal end of the insertion mandrills are optional connecting bars 17 which keep the relative spacial relationship of each insertion mandril constant. In this embodiment, as the helixes are withdrawn into the catheter, each one straightens out and is kept separate within the respective lumens. When the helixes are then deployed by translating the insertion mandril, the helixes reform the double helix configuration. The optional connecting bars 17 are used to ensure that each helix is being deployed by the translation of the insertion mandrills are in unison with each other such that the double helix configuration is always obtained upon full deployment.  
30  
35

FIG. 13 illustrates a long coil 140, ranging from about 2 cm to about 10 cm that is especially useful for removing clots in a surgically created arteriovenous fistula of a hemodialysis patient. The coil could also be used for removing long clots in the venous system and long clots in a surgically created by-pass graft. The arteriovenous fistulas are normally surgically created on the forearm of a hemodialysis patient and allows for easy access to the blood stream for hemodialysis treatment. Unfortunately, these fistulas often become clogged with long blood clots and have to be surgically repaired or a new fistula created. The long clot capture coil 140 is connected to the insertion mandril 16 at the coil's proximal end.

FIGS. 14 and 15 illustrate two further coil configurations. FIG. 14 is a cylindrical coil 150 attached to the distal end of the insertion mandril 16. FIG. 15 is a random tangle coil attached to the insertion mandril 16. The random tangle is manufactured by extruding the coil material in a random fashion. The random tangles made by such a process would vary each time the tangles are manufactured, and thus, the random tangle pictured in FIG. 15 is for illustration only.

FIGS. 10a and 10b illustrate the use of an introducer 72 with lumen 74. The introducer is a relatively short (10 to 20 mm long) single lumen catheter that is used to straighten the coil section of a shape memory coil which extends distally, such as the coils in FIGS. 2, 3, 6, and 7, prior to insertion into the catheter 12 of the present invention. A longer introducer would be used for the arteriovenous fistula coil of FIG. 13. The insertion mandril is inserted into the introducer in a retrograde direction (indicated by the arrow in FIG. 10a). Once the introducer reaches the shape memory coil section, the coil section straightens out almost to a complete straight line. In coil section that extend distally outward, the inner diameter of the introducer and the catheter are sized to be just slightly larger than the diameter of the insertion mandril and the coil section. That is, if the insertion mandril and the coil are each made from 0.008 inch diameter wires, then the inner diameter of the introducer is preferably 1 to 2 French. Once the coil has been straightened out completely, the coil within the introducer is aligned with the catheter and then advanced in an antegrade direction into the catheter.

The above detailed description describes some of the numerous embodiments of the present invention. Below is a discussion of some of the numerous uses of the invention.

In use, a patient presenting with symptoms of a thromboembolic disorder is examined radiographically using angiography to locate an occlusion and to confirm the diagnosis. A large introducing catheter 130 (see FIG. 12) is then inserted into an appropriate vessel (usually the femoral artery or the femoral vein). A small catheter or microcatheter 12 is then introduced into the vessel via the introducing catheter and advanced using a guide wire or the like into the occluded vessel. The catheter 12 is then passed through the viscoelastic clot. Once the catheter is in place and through the viscoelastic clot the clot capture coil is introduced into the catheter

5 using the insertion mandril and advanced to the distal tip of the catheter. For the shape memory  
clot capture coils that extend proximally from the insertion mandril (as in FIGS. 1a-1f, the coil  
and the insertion mandril are inserted directly into the proximal end of the catheter and advanced  
to the distal end (see FIG. 1b). For the shape memory clot capture coils that extend distally from  
10 the insertion mandril (as in FIGS. 2a-2e), the introducer of FIGS. 10a and 10b is used as  
described above. For the biphasic coils, the coils are introduced in the straight configuration by  
either having the straight configuration the natural configuration or by straightening a natural  
coil configuration by passing electric current or heating the coil.

Once the catheter and the clot capture coil have transversed the clot, the insertion mandril  
is translated distally relative to the catheter. With a shape memory coil, the coil deploys and  
reform its natural configuration outside the distal end of the catheter. By comparing FIGS. 1c  
and 2c it is apparent that the shape memory coils which extend distally from the insertion  
15 mandril immediately start to form the coil configuration once part of the coil is freed from the  
confines of the lumen of the catheter. These embodiments are particularly useful for clot  
removal in vessels that are small and/or tortuous where there is not much room for the  
advancement of the insertion mandril and the coil. In the embodiments where the shape memory  
coil extends proximally from the distal end of the insertion mandril, the entire length of the coil  
20 needs to be freed from the confines of the lumen of the catheter before it reforms the coil  
configuration. These embodiments are useful for the removal of large clots in large vessels  
because the coil is better supported and the coils can collapse upon each other. For example,  
as illustrated in FIGS. 1c-1f the proximal end of the coil which is a slidable loop 26 mounted  
around the insertion mandril will encounter the clot material first. The slidable loop then slides  
25 distally until the coils form a double inverted cone shaped configuration. The coils will overlap  
and thus give more support for the removal of large clots.

The biphasic coils are deployed similarly except that electric current or heat is used to  
form the coil configurations if the straight configuration is the natural shape. If the coil  
configuration is the natural shape, then the user stops applying electric current or heat and the  
30 coil configuration will reform.

The clot is then retrieved by translating the insertion mandril along with the catheter  
proximally. When the clot capture coil is pulled proximally the clot becomes ensnared.  
Additionally, while pulling proximally on the insertion mandril, the coil is rotated by rotating  
the insertion mandril to transfix the clot by corkscrewing the clot into the coils. The viscoelastic  
35 properties of the clot allow the clot to be captured within the side coils and to be pulled down  
using the most distal coils as a capture cup. The clot can then be completely removed or released  
into a vessel that does not perfuse a critical organ such as an external carotid artery.

A particularly useful introducing catheter is illustrated in FIG. 11. The introducing

5 catheter 110 is hollow with a single lumen and has a Y junction towards its proximal end. The  
introducing catheter is a standard commercially available introducing catheter. The introducing  
catheter has two ports, 112 and 114. Port 112 is in straight communication with the longitudinal  
axis of the introducing catheter and is useful for the insertion of the catheter 12, coil 30 and  
insertion mandril 16 of the present invention. The other port which is angled away from the  
longitudinal axis of the insertion catheter is for the attachment to a suction line from a vacuum  
source. Located at the distal end 116 of the introducing catheter is a marker band 118 that can  
10 be located via radiographic means while the introducing catheter is being used.

In practice, the introducing catheter 110 is inserted through a large vessel and through the  
vascular system to a position near a clot in an occluded artery under fluoroscopic guidance. The  
catheter 12, is then inserted through port 112 and through the introducing catheter such that the  
distal end of the catheter 12 has passed the distal end 116 of the introducing catheter. The  
15 catheter 12 is then translated across the clot. The coil 30 and insertion mandril 16 are then  
inserted into the catheter 12. The insertion mandril is then translated through the catheter 12  
until the coil 30 is deployed in the vessel. The insertion mandril is then translated proximally  
to ensnare the clot within the coil and then the catheter, coil and clot are translated toward the  
distal end 116 of the introducing catheter 110. Once the clot and the coil are at the distal end  
20 116, suction is applied via port 114 to suck part of the clot into the distal end 116. The suction  
helps to keep the clot within the coil. Then the introducing catheter 110, the catheter 12, the clot  
and the coil 30 are removed from the patient.

FIG. 12 illustrates the invention being used as a filter in the inferior vena cava of a patient  
with a venous thrombus in a lower limb. A commercially available introducing catheter 130 is  
25 advanced into a femoral vein 122 and into the inferior vena cava 128 below the heart 126. A  
catheter 12 is then advanced through the introducing catheter. The coil 120 and insertion  
mandril 16 are then advanced through the catheter 12 and the coil 120 is deployed within the  
inferior vena cava. The coil 120 has a large diameter, around 20 mm to 30 mm, such that when  
deployed it fits snugly within the inferior vena cava. The coil acts as a filter wherein pieces of  
30 the thrombus become trapped in the coil instead of being transported to the lungs. The thrombic  
material can then be removed from the patient.

Foreign bodies are removed as described above except that the foreign body becomes  
ensnared in the clot capture coil instead of a clot. Due to the numerous coils, it is much easier  
to ensnare a foreign body than using a loop type device.

35 The following examples illustrate some of the uses of the invention. The examples are  
provided for illustration purposes and are not meant to limit the invention to the specific  
examples.

### EXAMPLE 1

5 The clot capture coil was clinically tested in pigs. In the first study a pig's femoral artery was isolated and a large commercially available introducing catheter was inserted into the femoral artery. Arterial blood was then withdrawn and allowed to clot *in vitro*.

An arterial catheter was then inserted through the introducing catheter and into the carotid artery. The coagulated arterial blood was then released into the carotid artery branches via the arterial catheter resulting in the formation of numerous emboli.

10 Angiography was used to locate the emboli. While performing angiography a microcatheter (outer diameter of 3 French and inner diameter of 1 French) was inserted into an occluded carotid artery using a guide wire for placement and standard microcatheter placement techniques. The microcatheter was advanced distally past the clot. The guide wire was then withdrawn from the microcatheter.

15 A shape memory clot capture coil connected to an insertion mandril was then introduced into the microcatheter using a small introducer. The coil configuration was the type illustrated in FIG. 2a. Because the coil extends distally from the insertion mandril a small introducing catheter had to be used to introduce the clot capture coil into the microcatheter. The insertion mandril and the clot capture coil was inserted in a retrograde direction into the introducing catheter. The inner diameter of the introducing catheter was identical to the microcatheter. The clot capture coil became straight due to the superelastic properties of the coil and the small inner diameter of the introducer. Once the coil was completely within the introducer, the introducer was aligned with the microcatheter and the coil was inserted into the microcatheter in an anterograde direction.

25 The clot capture coil was slowly advanced to the distal end of the microcatheter by translating the insertion mandril. As the insertion mandril was advanced, the coil began to be expressed from the distal end of the microcatheter. As more and more of the coil was expressed, the coil deployed and returned to its natural resting coiled shape as in FIG. 2c.

30 The clot capture coil was then pulled proximally to ensnare the clot. While pulling proximally, the coil was rotated by rotating the insertion mandril to transfix the clot by corkscrewing the clot into the coils. The clot was then completely removed from the pig by removing the microcatheter, insertion mandril, and the clot within the clot capture coil from the pig's femoral artery.

### EXAMPLE 2

35 The procedure of example 1 was repeated using a shape memory clot capture coil configuration illustrated in FIG. 3. The clot was successfully corkscrewed and ensnared and removed from the pig's occluded cerebral artery.

**EXAMPLE 3**

5 The procedure of example 1 was repeated using a shape memory clot capture coil as illustrated in FIG. 4. Because this embodiment has the coil extending proximally from the distal end of the insertion mandril, the clot capture coil was directly inserted into the microcatheter without the use of a small introducer. A clot in an occluded carotid artery was ensnared in the coil and completely removed.

10 Thus, a clot capture coil is disclosed which allows for the removal of thromboembolic material and foreign bodies from a blood vessel. While embodiments and applications of this invention have been shown and described, it would be apparent to those skilled in the art that many more modifications are possible without departing from the inventive concepts herein. The invention, therefore, is not to be restricted except in the spirit of the appended claims.

15

20

25

30

35

**WHAT IS CLAIMED IS:**

- 5           1.     A clot capture coil device comprising:  
          (a)    a catheter with at least one lumen;  
          (b)    an insertion mandril with proximal and distal ends wherein the insertion  
mandril is capable of being inserted into the lumen of the catheter; and  
          (c)    a solid shape memory coil with proximal and distal ends wherein one of the  
10           ends of the coil is connected to the distal end of the insertion mandril and the other end of the  
coil is freely movable.
2.     A clot capture coil device of claim 1 wherein the coil is elastic.
- 15           3.     A clot capture coil device of claim 1 wherein the coil is superelastic.
4.     A clot capture coil device of claim 1 wherein the coil comprises a solid nitinol  
wire.
- 20           5.     A clot capture coil device of claim 1 wherein the proximal end of the coil is  
connected to the distal end of the insertion mandril.
6.     A clot capture coil device of claim 1 wherein the distal end of the coil is connected  
to the distal end of the insertion mandril.
- 25           7.     A clot capture coil device of claim 1 wherein the diameter of the coil ranges from  
about 1 mm to about 30 mm.
8.     A clot capture coil device of claim 1 wherein the length of the coil ranges from  
30           about 3 mm to about 100 mm.
9.     A clot capture coil device of claim 8 wherein the length of the coil ranges from  
about 3 mm to about 20 mm.
- 35           10.    A clot capture coil device of claim 6 wherein the coil is inserted within the lumen  
of the catheter and the coil section is deformed to form a substantially straight line and extends  
distally from the distal end of the insertion mandril.



11. A clot capture coil device of claim 1 wherein the coil is barrel shaped.
- 5 12. A clot capture coil device of claim 1 wherein the coil is conically shaped.
13. A clot capture coil device of claim 1 wherein the coil is cup shaped.
14. A clot capture coil device of claim 1 wherein the coil is cylindrically shaped.
- 10 15. A clot capture coil device of claim 1 wherein the coil is a random tangle.
16. A clot capture coil device comprising:
- 15 (a) a catheter with at least one lumen;
- (b) at least one insertion mandril with proximal and distal ends wherein the insertion mandril is capable of being inserted into the lumen of the catheter; and
- (c) a solid shape memory coil with two ends wherein the coil is shaped to form a double helix and the ends of the coil are connected to at least one insertion mandril.
- 20 17. A clot capture coil device of claim 16 wherein the coil is elastic.
18. A clot capture coil device of claim 16 wherein the coil is superelastic.
19. A clot capture coil device of claim 16 wherein the coil comprises a solid nitinol
- 25 wire.
20. The clot capture coil of claim 16 wherein the catheter has one lumen and there is only one insertion mandril and wherein both ends of the coil are connected to the distal end of the insertion mandril.
- 30 21. The clot capture coil of claim 16 wherein the catheter has at least two lumens and there are two insertion mandrills, and wherein each end of the coil is connected to a different insertion mandril.
- 35 22. A method of removing a clot or foreign body in a vessel of a patient comprising the steps of:
- (a) inserting a catheter with at least one lumen passed the clot or foreign body;
- (b) inserting a solid shape memory coil connected at one of its ends to an

insertion mandril into the lumen of the catheter whereby the coil deforms to an essentially straight configuration;

5 (c) advancing the coil to the distal end of the catheter by translating the insertion member distally;

(d) advancing the coil distally out of the catheter to deploy the coil to allow the shape memory coil to reform its natural coil configuration;

10 (e) translating the coil across the clot or foreign body by translating the insertion mandril proximally relative to the catheter to thereby ensnare the clot or foreign body;

(f) moving the clot or foreign body out of the vessel by moving the catheter, coil and insertion mandril out of the vessel.

23. The method of claim 22 wherein the coil comprises is elastic.

15

24. The method of claim 22 wherein the coil comprises is superelastic.

25. The method of claim 22 wherein the coil comprises a solid nitinol wire.

20

26. The method of claim 22 wherein a clot is removed and wherein the viscoelastic properties of the clot are utilized to ensnare the clot and corkscrew the clot with the coil.

27. The method of claim 22 further comprising the step of:

25

(g) removing the clot or foreign body entirely from the patient's body.

28. The method of claim 27 wherein the clot removed was a clot within the cerebral vasculature.

30

29. The method of claim 27 wherein the clot removed was a clot within the coronary vasculature.

30. The method of claim 27 wherein the clot removed was a clot within the peripheral vasculature.

35

31. The method of claim 27 wherein the clot removed was a clot within a surgically created arteriovenous fistula.

32. The method of claim 27 wherein the clot removed was a clot within a the venous

system.

5           33.    The method of claim 27 wherein the clot removed was a clot within a by-pass graft.

34.    A method of filtering thrombic material in a vessel comprising the steps of:

(a)    inserting a catheter with at least one lumen into the vessel;

10           (b)    inserting a solid superelastic shape memory coil connected at one of its ends  
to an insertion mandril into the lumen of the catheter whereby the coil deforms to an essentially  
straight configuration;

(c)    advancing the coil to the distal end of the catheter by translating the insertion  
member distally;

15           (d)    advancing the coil distally out of the catheter to deploy the coil to allow the  
superelastic shape memory coil to reform its natural coil configuration;

(e)    allowing blood to flow through the coil to thereby filter any thrombic  
material contained in the blood and to trap the thrombic material within the coil;

(f)    moving the thrombic material out of the vessel by moving the catheter, coil  
and insertion mandril out of the vessel.

20

35.    A clot capture coil device comprising:

(a)    a catheter with at least one lumen;

(b)    an insertion mandril with proximal and distal ends wherein the insertion  
mandril is capable of being inserted into the lumen of the catheter; and

25           (c)    a biphasic coil with proximal and distal ends wherein one of the ends of the  
coil is connected to the distal end of the insertion mandril and the other end of the coil is freely  
movable.

30

36.    A clot capture coil device of claim 35 wherein the coil comprises a solid biphasic  
nitinol wire.

35

Fig. 1a

Fig. 1b

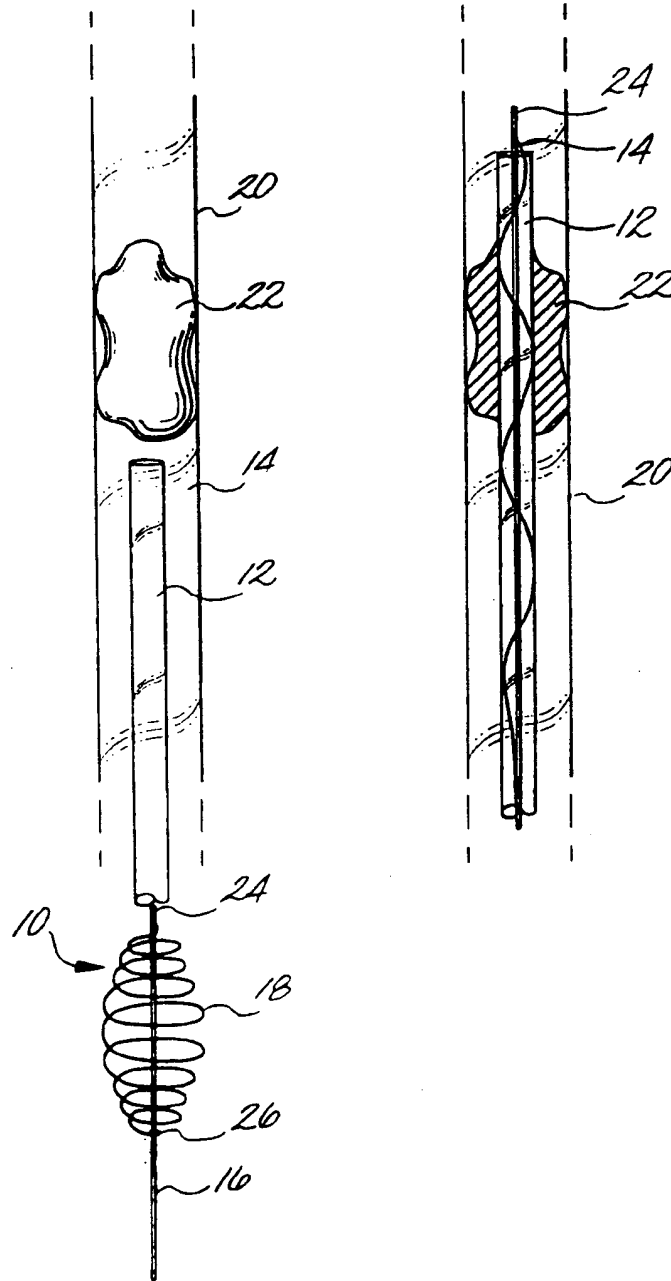

*Fig. 1C*

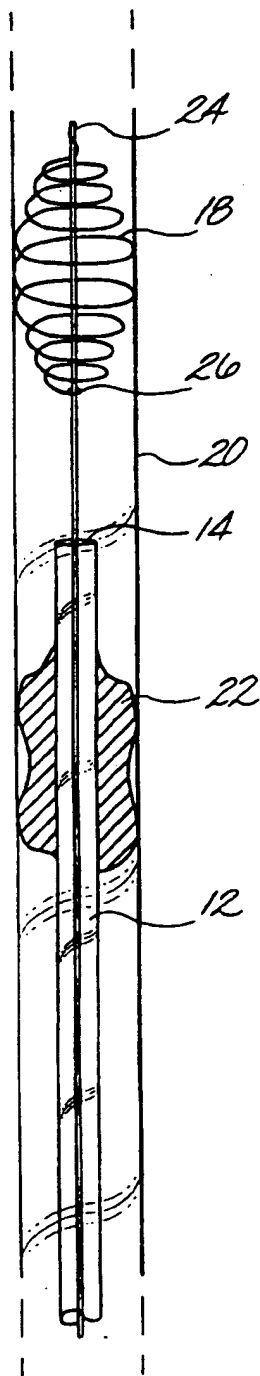
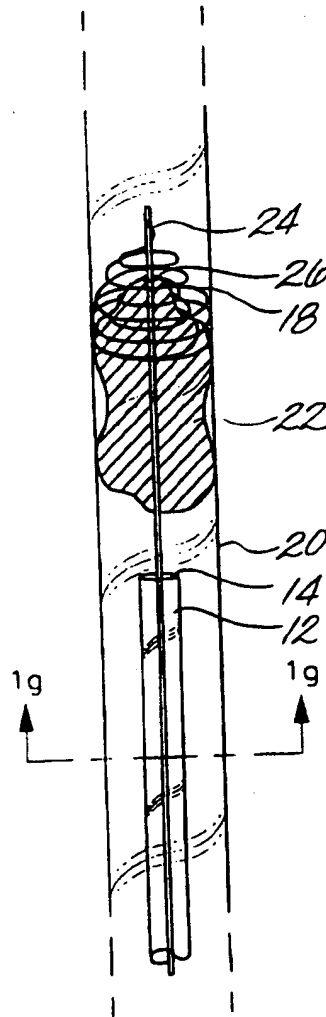
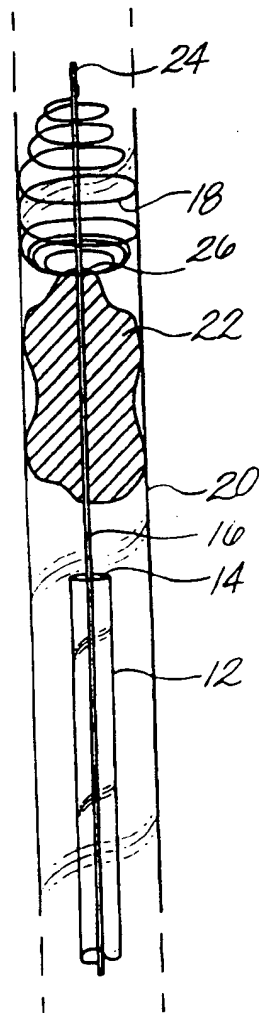
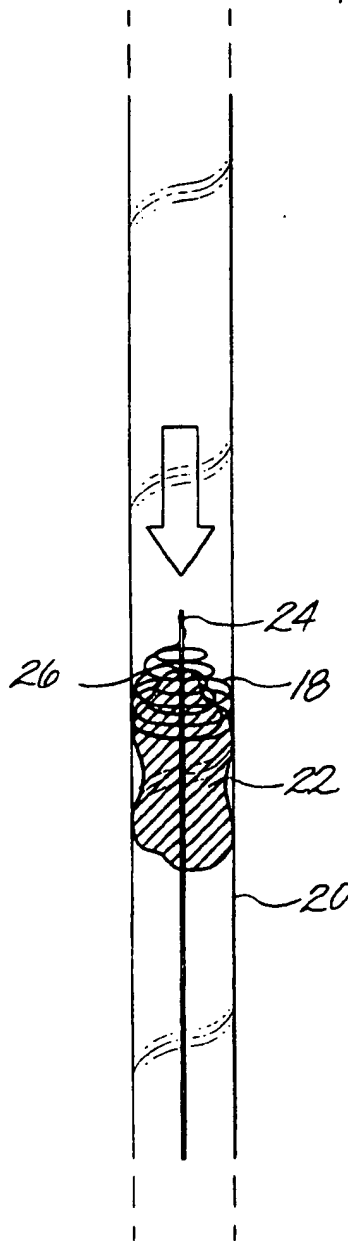

Fig. 1d

Fig. 1c



*Fig. 1f*



THIS PAGE BLANK (USPTO)

THIS PAGE BLANK (USPTO)